



THE POWER OF QUALITY



80 KW SERIES

1104D-E44TAG1

Diesel Engine - ElectropaK

80 kW @ 1800 rev/min



Power to Meet your Needs

Hitting the key power nodes required by the market, the 1104D-E44TAG1 ElectropaK has been developed to provide a clean and cost effective power solution.

State of the Art Design

The 1104D utilises the latest common-rail fuel system technologies with a closely optimised air-management system, which is overseen by the latest generation of electronic engine control. This allows the 1104D range to deliver high power density and excellent fuel economy with low exhaust emissions and minimum heat rejection.

Worldwide Power Solution

The 1104D has been designed to be worldwide fuel tolerant, and 5% biofuel (RME) options are available to meet local market needs.

World-class Product Support

At Triton Power we are constantly researching, developing and investing in our products and services. Total worldwide support is provided through a network of distributors and service outlets, providing access to over 50,000 parts and exchange units 24 hours a day, 365 days a year. This support is enhanced by TIPSS (The Integrated Parts and Service System). TIPSS enables customers to electronically specify and order parts as well as service 1104D engines with online guides and service tools.

Lower Operating Costs

The 1104D maintains Tier 2 fuel economy. This will allow many customers to keep existing fuel tanks, avoiding the need for costly redesign. Service intervals are set at 500 hours as standard and Perkins provides comprehensive warranty cover for two years, with three years on major engine components. A low usage warranty package is also available.

Long-term Power Solution

The 1104D-E44TAG ElectropaK range has been designed to fully comply with stringent EPA Tier 3 emissions regulations, providing an emissions compliant power solution for the future.

Certified against the requirements of Tier 3 legislation for non-road mobile machinery, powered by constant speed engines (EPA Part 89 Tier 3). 40 CFR

The 1104D-E44TAG ElectropaKs are the latest addition.

Offering improved power density from a compact package, these ElectropaK's build on Triton Power 80 kW Series reputation within the Power Generation Industry.

These ultra clean engines are assembled on a new high technology production line. Frequent computerised checks during the production process ensure high build quality is maintained throughout.

Hitting the key power nodes required by the market, the 1104D ElectropaK product line-up consists of three models offering a power solution for both Prime and Standby applications, in 60 Hz territories.

Engine speed (rev/min)	Type of Operation	Typical generator output (net)		Engine power			
		kVA	kWe	Gross		Net	
				kWm	bhp	kWm	bhp
1800	Prime	90.0	72.0	106.0	142.1	100.0	134.1
	Standby (maximum)	100.0	80.0	117.0	156.8	111.0	148.8

The above ratings represent the engine performance capabilities to conditions specified in ISO 8528/5

Derating may be required for conditions outside the test conditions; consult Triton Power Corp.

Generator powers are typical and are based on typical alternator efficiencies and a power factor

Fuel specification: Consult Triton Power Corp (various fuel specifications are available)

Lubricating oil: multi-grade oil conforming to API-CH4/CI4 must be used

Rating Definitions

Prime Power: Power available at variable load in lieu of a main power network. Overload of 10% is permitted for 1 hour in every 12 hours' operation

Standby (maximum): Power available at variable load in the event of a main power network failure. No overload is permitted

All information in this document is substantially correct at time of printing and may be altered subsequently

80 KW Series

1104D-E44TAG1

Standard ElectropaK Specification

Air inlet

- Mounted air filter and turbocharger

Cooling system

- 22" belt-driven pusher fan and guards
- Radiator (incorporating air-to-air charge cooler)
- Water pump

Electric system

- 12 volt starter motor
- 12 volt, 65 amp alternator with DC output

Flywheel and housing

- High inertia flywheel to SAE J620 Size 10/11 1/2
- SAE3 flywheel housing

Fuel system

- Electronic governing (conforms to Class G3 ISO 8528-5)
- Fuel filter

Literature

- Users Handbook

Lubrication system

- Wet cast iron sump with filler and dipstick
- Oil filter

Start aids

- Glow plugs

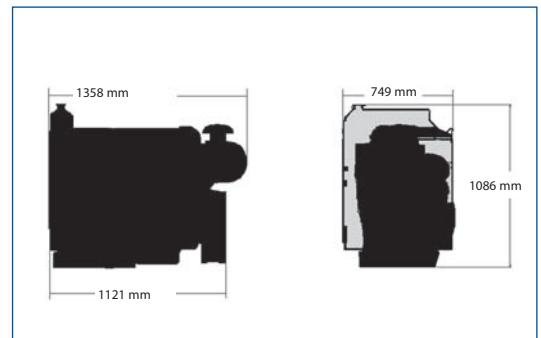

Fuel Consumption		
Power Rating %	1800 rev/min	
	g/kWh	l/hr
110	214.7	30.0
100	216.3	27.7
75	231.5	22.0
50	253.1	16.0

General Data

Number of cylinders	4 in-line
Bore and stroke	105 mm x 127 mm
Displacement	4.41 litres
Aspiration	Turbocharged air-to-air chargecooled
Cycle	4 stroke
Combustion system	Direct injection
Compression ratio	16.2:1
Rotation	Anti-clockwise viewed on flywheel
Cooling system	Water-cooled
Total lubrication system system capacity	8 litres
Total coolant capacity	17 litres
Dimensions	Length 1358 mm Width 749 mm Height 1086 mm
Dry weight	465 kg
Wet weight	474 kg

Final weight and dimensions will depend on completed specification.



TRITON POWER CORP
8511 NW 61ST STREET
MIAMI, FL 33166
T: 305-592-6800
F: 305-592-5900
WWW.TRITONPOWER.COM

Distributed by