

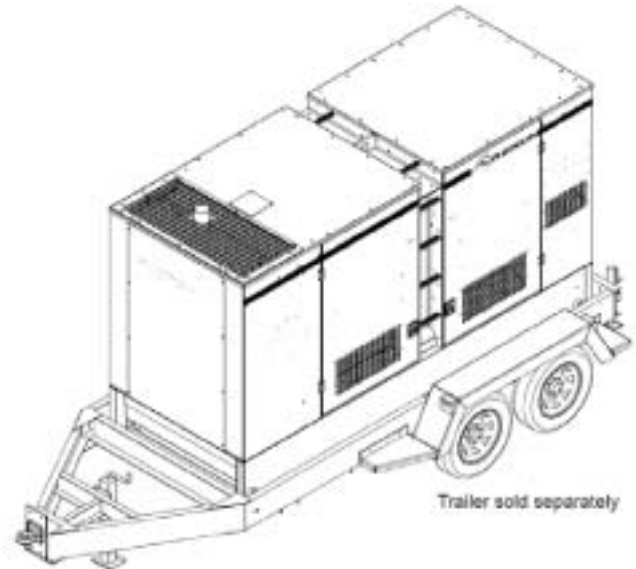

Mobile Generator – AG320 Specifications

ENGINE

- John Deere® RG6090HF485 - turbocharged, diesel engine
 - Prime - 422 hp @ 1800 rpm
 - 6 cylinder
 - 9.0 L displacement
 - Tier III approved
- Steel, single wall fuel tank
 - 459 gal. capacity
 - 24 hr. run time – full load
 - Fuel tank built into skid of generator set
- Fuel consumption at prime:
 - 100% - 17.9 gph (67.8 Lph)
 - 75% - 13.4 gph (50.7 Lph)
 - 50% - 9.0 gph (34.1 Lph)
- Cooling system capable of operating at 120°F ambient
- Low coolant shutdown
- Radiator and oil drains plumbed to exterior
- Rubber vibration dampers isolate engine/generator from frame
- In-line engine block heater
- Disposable air filter - paper element
- Air filter restriction indicator mounted on control panel
- 60 Hz engine/generator
- Electronic isochronous governing



GENERATOR

- Marathon Electric®
 - Brushless
 - 4 pole
 - Class H insulation
- Voltage regulation +/- 1% with Marathon SE350 Voltage Regulator

SYSTEM OUTPUT

- Link / Reconnect Board:
 - Three phase – 120 / 208V Low Wye
 - Three phase – 277 / 480V High Wye
- 278 kW / 348 kVA – standby, three phase
- 256 kW / 320 kVA – prime, three phase

SYSTEM CONTROLS

- Microprocessor-based controller
 - Backlit, 128x64 pixel resolution display
 - 40°F to 185°F operating temperature range
 - Thermostatically controlled LCD heater
 - Six LED indicators w/ lamp test
 - Alarm / Fault (Red)
 - Ready / Manual (Red)
 - Running (Green)
 - Warning (Yellow)
 - Ready / Auto (Green)
 - Supplying Load (Green)
- Push buttons for easy operation
 - Manual or Auto Start
 - Engine Start or Stop
 - Alarm Cancel & Fault Reset
 - Scrolling Arrows for Diagnostic Information
 - System kW output display
 - Line output & frequency display
 - Engine diagnostic display
 - Oil pressure
 - Engine temperature
 - Fuel level
 - Battery
 - System hours
 - Running hours
 - kW hours
 - Time to service
 - Alarm list – warnings / shutdowns are date & time stamped
 - Fuel level: warning – 15%; shutdown – 5%
 - Overspeed protection: shutdown – 115%
 - Oil pressure: warning – 25 psi; shutdown – 20 psi
 - Coolant temperature: warning – 220°F; shutdown – 230°F
 - Battery voltage: over – 15VDC; under – 11VDC
 - Generator over voltage: warning – 110%; shutdown – 111%
 - Generator under voltage: warning – 87%; shutdown – 86%
 - Generator over frequency: warning – 105%; shutdown – 110%
 - Generator under frequency: warning – 95%; shutdown – 90%
 - Over current shutdown

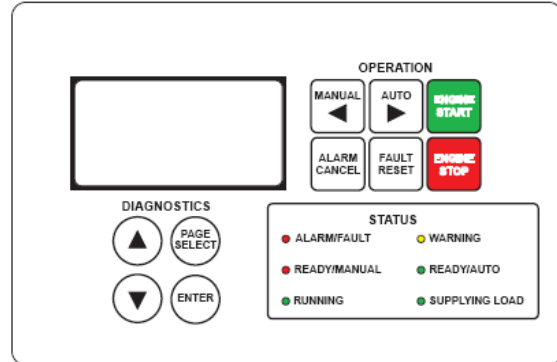

ELECTRICAL CONTROLS

- Remote start / stop contacts located next to lug box
- Lockable control box door with diagnostics window
- Lockable lug box with safety switch
 - Trips main breaker when lug door is opened
 - Disables voltage regulator

- Cable entry guides to the lug box
 - Restricts access of foreign objects
- Output ground connection lug inside lug box
- 1200A main breaker with shunt trip
- Convenience receptacles with individual breakers (restricted use in high wye mode)
 - (2) 120V 20 Amp GFCI duplex outlets (Nema 5-20R type)
 - (3) 125 / 250V 50 Amp, 3 pole, 4 wire twistlock (Non-Nema 6369)
 - Buck Transformer kit – Provides 120V at GFCI outlets when in 277/480V
- Panel mounted rheostat for voltage adjustment - +/- 10%
- (2) 1000 CCA wet cell batteries
 - Battery disconnect switch
 - 2A trickle battery charger

ENCLOSURE

- Aluminum, sound attenuated enclosure
 - UV & fade resistant, high temperature cured, white polyester powder paint
 - Insulated and baffled
 - 68 dB(A) at 23 feet – prime power
- Fully lockable enclosure including doors and fuel fill
- Stainless steel hinges on doors
- Emergency stop switch located on outside of enclosure
- Central lifting point
- Multi-lingual operating/safety decals
- Document holder with operating/parts manuals including AC/DC wiring diagrams

TRAILER

- DOT approved tail, side, brake, and directional lights
 - Recessed rear lights
- Transportation tie downs
- Safety chains with spring loaded safety hooks
- 3" lunette ring hitch
- (2) 8000 lb. axles with electric brakes
- 15000 lb. tongue jack with footplate
- ST215/75R17.5 tubeless tires – 16 ply

WEIGHTS & DIMENSIONS

Skid mounted

- Dry weight: 8300 lbs (3765 kg)
- Operating weight: 11000 lbs (4990 kg)
- 156 x 60 x 90 in
(3.96 x 1.52 x 2.29 m)

Trailer mounted

- Dry weight: 10300 lbs
(4672 kg)
- Operating weight: 13000 lbs
(5897 kg)
- 230 x 102 x 110 in
(5.84 x 2.59 x 2.79 m)

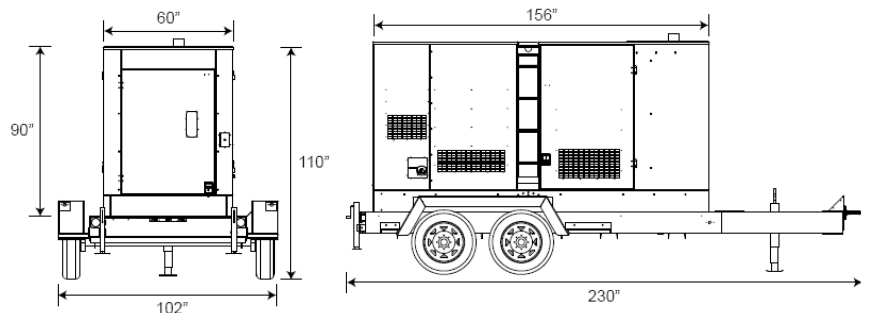

WARRANTY

- Engine and generator covered under OEM warranty – consult factory for details.

CERTIFICATIONS

- CSA certified
-

AG320 Options

GENERATOR OPTIONS

- PMG Generator - critical grade power quality
- Super Start Generator - motor starting applications

VOLTAGE OUTPUT OPTIONS

- 4 position phase switch
 - Single phase – 120 / 240V Zig Zag
 - Three phase – 120 / 208V Low Wye
 - Three phase – 277 / 480V High Wye
 - Three phase – 120 / 240V Delta
- Dedicated voltage configurations
- Cam locks

SYSTEM CONTROLS OPTIONS

- Auxiliary strobe/audible indication for soft & hard alarm conditions

COOLANT OPTIONS

- 60/40 Coolant - cold weather applications

ENCLOSURE OPTIONS

- Fire extinguisher
- Interior cabinet light
- Control panel light

FUEL TANK OPTIONS

- 36 hr. single wall fuel tank
- 120% Containment
- Fuel transfer pump

TRAILER OPTIONS

- 6 pin or 7 spade electrical connectors
- Spare tire/wheel kit

HITCH OPTIONS

- Adjustable height - 3” lunette ring