



# HP SERIES

Power Range	kW	kVA	MODELS:
Standby	62.5 - 81	62.5 - 101.2	HP - 80
Prime	62.5 - 73	62.5 - 91.2	HP - 80

## STANDARD EQUIPMENT

Open Set Model: HP-80	Accessories Available for HP-80
<ul style="list-style-type: none"> <li>■ Skid with integral day fuel tank (non-UL)</li> <li>■ Deep Sea 5210 digital auto-start control panel</li> <li>■ Dry-type replaceable element air-cleaner</li> <li>■ Industrial muffler</li> <li>■ Battery, battery rack, and cables</li> <li>■ Fuel and lubrication oil replaceable element filters</li> <li>■ Stamford AVR brushless 12-wire reconnectable alternator</li> <li>■ Oil drain hand pump</li> <li>■ Vibration Isolators between base and set assembly</li> <li>■ Main Line Circuit Breaker for overload protection</li> <li>■ Belt driven charging alternator</li> <li>■ Guards for shielding all rotating parts</li> <li>■ Fuel cut-off solenoid and protection switches</li> <li>■ Radiator with pusher fan</li> <li>■ Operation and installation manuals</li> </ul>	<p style="text-align: center;"><u>Mechanical Accessories Offered</u></p> <ul style="list-style-type: none"> <li>■ Weather protective canopy (for Open Set)</li> <li>■ Road towing trailers to DOT standards</li> <li>■ Critical grade exhaust mufflers</li> <li>■ UL double wall fuel tanks to customer specification</li> <li>■ Oil field type skid</li> <li>■ Flexible exhaust connection for open sets</li> <li>■ Oil pressure and engine temperature gauges</li> <li>■ Extended warranty coverage above the standard one year</li> </ul> <p style="text-align: center;"><u>Generator End Accessories Offered</u></p> <ul style="list-style-type: none"> <li>■ PMG excitation for enhanced motor-starting</li> <li>■ Anti-condensation heaters in alternator</li> </ul> <p style="text-align: center;"><u>Electrical and Control Accessories Offered</u></p> <ul style="list-style-type: none"> <li>■ Automatic battery chargers 5 and 10 amp</li> <li>■ NFPA 110 controls and remote annunciator</li> <li>■ Analog instrumentation in lieu of digital</li> <li>■ Transfer switch and paralleling control panels</li> <li>■ Water Jacket Heater</li> <li>■ Remote control from PC via hard and/or wireless link</li> <li>■ GPS for mobile sets</li> <li>■ Digital Timer (Auto-start sets only)</li> </ul>
<p style="text-align: center;"><b>Sound Attenuated Set Model: HP-80</b></p> <ul style="list-style-type: none"> <li>■ Fully sound attenuated enclosure (equipped as open set)</li> <li>■ Powder Painted with finish that exceeds 1000-hr salt test</li> <li>■ Rock wool insulation behind protective barrier</li> <li>■ Curved edges and minimum outside fasteners</li> <li>■ Single lifting point</li> </ul>	

## GENERATOR RATINGS

Alternator	Voltage	Ph	Hz	Standby Rating		Prime Rating	
				kW/kVA	Amps	kW/kVA	Amps
	120 / 208	3	60	80 / 100	277	72 / 90	250
	127 / 220	3	60	80 / 100	262	72 / 90	236
	120 / 240	3	60	80 / 100	240	72 / 90	216
UCI 224G	139 / 240	3	60	81 / 101.2	243	73 / 91.2	219
	277 / 480	3	60	81 / 101.2	122	73 / 91.2	110
	347 / 600	3	60	81 / 101.2	97	73 / 91.2	88
	120 / 240	1	60	62.5	260	62.5	260
UCI 274D	120 / 240	1	60	78	325	71	295

## Application Data

Alternator Specifications		Engine Mechanical Specifications	
Manufacturer	Newage Stamford	Manufacturer	Perkins
Type	4-pole, rotating field	Engine model	1104D E44TAG1
Exciter type	Brushless, self excited. (PMG option)	Engine type	4-cycle, Turbocharged After-cooled
Leads: quantity, type	12, reconnectable	Cylinder arrangement	4 in line
Voltage regulator	Solid state, volts/Hz and excitation overload protection	EPA Certification :	TIER 3
Insulation:		Displacement, L (cu. in.)	4.4 (269)
Material.....	Class H	Bore and stroke, mm (in.)	105 x 127 (4.13 x 5.0)
Temperature rise.....	150° C , standby	Compression ratio	18.3 : 1
Bearing: quantity, type	Single bearing sealed	Piston speed, m/min. (ft./min.)	457 (1,500)
Coupling	Flexible disc	Main bearings: quantity, type	5, replaceable insert
Amortisseur Windings	Full	Rated rpm	1,800
Voltage regulation, no-load to full load	± 1.0% (with PMG) ± 1.5% (with Self Excited)	Max. power at rated rpm, kWm (BHP)	94 (126)
Unbalanced load capability	100% of rated standby current	BMEP, gross, psi ( Bar )	206.5 (14.2)
Load acceptance	Per ISO - 8528	Overall thermal efficiency	38.7%
Peak motor starting kVA:	(30% dip)	Exhaust Gas Flow, m <sup>3</sup> /min (cfm)	16.5 (584)
480 V	self-excited series 4 - 270 kVA	Exhaust gas temperature °C (°F)	476 (889)
480 V	PMG series. 3 - 325 kVA		
Engine Electrical Specifications		Frequency regulation, no-load to full load	0.25%
Engine Electrical System (12 Volt) 60 Hz		Governor: Type:	Electronic Isochronous
Battery charging alternator:		Make:	Perkins
Ground (negative/positive).	Negative	Standard:	ISO 8528 class G3
Volts (DC).....	12V	Frequency regulation, steady state	± 0.5%
Ampere rating.....	55A	Frequency	Fixed
Starter motor rated voltage (DC)	12V	Air cleaner type	Dry
Starter motor rated kW:	3.0 Kw		
Battery CCA rating:	810A		
Battery & qty, AH rating:	1 x 90AH		
Battery Voltage (DC)	12V		
Remote Radiator System		Fuel Consumption 60 Hz	
Exhaust manifold type		Diesel gal/hr (L/hr)	Standby Rating
Connection sizes:		100%	6.4 (24.19)
Water inlet ID hose, mm (in)		75%	4.9 (18.52)
Water outlet ID hose, mm (in)		50%	3.4 (12.85)
Charge air cooling (CAC)	Not Available	25%	1.9 (7.18)
Water inlet ID hose, mm (in)		Diesel gal/hr (L/hr)	Prime Power Rating
Water outlet ID hose, mm (in)		100%	5.8 (21.92)
Static head allowable above engine, ft.H <sub>2</sub> O (kPa)		75%	4.5 (17.00)
Maximum CAC restriction H <sub>2</sub> O in.		50%	3.1 (11.718)
Contact us for special cooling options		25%	1.7 (6.42)

## Application Data

Cooling		Lubrication	
<b>Radiator Systems</b>	<b>60 Hz</b>	<b>Lubricating System</b>	<b>60 Hz</b>
Ambient temperature, °C (°F)	46 (115)	Type	Full pressure
Engine jacket water capacity L (gal)	7.0 (1.8)	Oil pan capacity, L, (qt.)	5.5 (5.8)
Radiator system capacity, including engine, L (gal.)	12.6 (3.3)	Recommended lube oil	API CG4/CH4
Engine jacket water flow, L/min (g/min)	170 (44.9)	Oil pan capacity with filter, L (qt.)	8.0 (8.5)
Heat rejected to cooling water at rated kW, dry exhaust, kW (Btu/min.)	51.0 (2.901)	Oil filter: quantity, type	1, cartridge
Heat rejected to charge cooler at rated kW, dry exhaust, kW (Btu/min.)	11.0 (626)	Oil cooler	Oil to water
Water pump type	Centrifugal	Normal oil temperature, °C(°F)	110 (230)
Fan, kWm (HP)	4.7 (6.3)	<b>Ventilation and Air-Flow Requirements</b>	
Max. restriction of cooling air, intake and discharge side of radiator, Pa (in. H <sup>2</sup> O)	62.2 (0.25)	<b>Air Requirements</b>	<b>60 Hz</b>
dBA LEVELS SOUND ATTENUATED ENCLOSED	Within (under) 70dBA @ 21 feet	Radiator-cooled cooling air, m <sup>3</sup> /min. (scfm)	225.6 (7,966)
		Air density kg/m <sup>3</sup> (ibm/ft <sup>3</sup> )	1.20 (0.075)
		Heat rejected to exhaust, kW (btu/min)	79.4 (4,516)
		Heat radiated to surrounding air Engine: kW (Btu)	7.5 (427)
		Combustion air, m <sup>3</sup> /min. (cfm)	7.5 (263)

## Dimensions and Weights

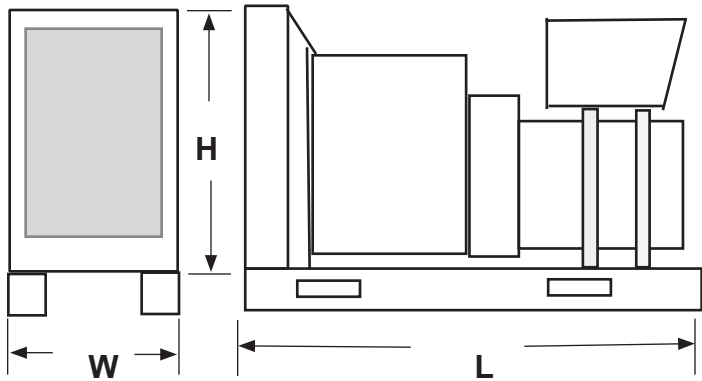
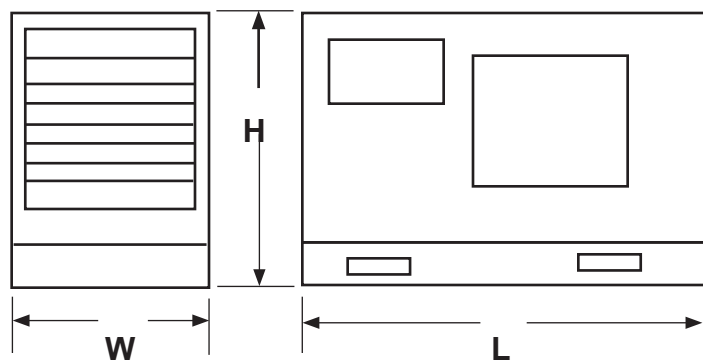
Open Set Model: HP-80		Sound Attenuated Set Model: HP-80	
Overall size, L x W x H, mm (ins.)	1,820 x 630 x 1,390 (71.65 x 24.8 x 54.72)	Overall size, L x W x H, mm (ins.)	2,750 x 1,100 x 1,550 (108.26 x 43.30 x 61)
Weight, radiator-mounted model, wet, kg (lb.):	984 (2,165)	Weight, radiator-mounted model, wet, kg (lb.):	1,680 (3,696)
Fuel Tank Capacity, L (US gal)	145 (38.3)	Fuel Tank Capacity, L (US gal)	176 (46.5)
			

NOTE: The drawings above are only representative of the overall dimensions. For full detailed installation drawings please consult your distributor.

**RATINGS:** Power factor three-phase is 0.8 and single-phase unity. Standby Ratings: Standby ratings assume installation normally served by reliable utility power. The standby rating is available for varying loads for the length of the power outage. No overload is available with the standby rating. Ratings are in accordance with ISO-3046/1 and DIN 6271. Prime Power Ratings: Prime power ratings assume no or unreliable utility power. For varying loads the generator set has unlimited operating hours. A 10% overload capacity is available for any 1 hour in a 12 hour continuous running period. Ratings are in accordance with ISO-3046/1 and DIN 6271. Consult Himoinsa for limited running time and base load ratings. Himoinsa reserves the right to change the design or specifications without notice and without any obligation or liability whatsoever. DERATION GUIDELINES: Altitude: Derate 1.3% per 100 m (328 ft) elevation above 1000 m (3280 ft). Temperature: Derate 1.0% per 10°C (18°F) temperature above 40°C (104°F).