

CODE	MOUNTING ARRANGEMENT	ADAPTER						DRIVE DISC						
		SAE SIZE	H	J	XB	XC	XD	SAE SIZE	K	M	XE	XF	XG	XJ
A	11	#3	12	11.18	428.75	639.83	409.575	#11 1/2	8	10.41	352.400	333.25	39.62	15.75
B	21	#2	12	11.18	466.85	639.83	447.675	#11 1/2	8	10.41	352.400	333.25	39.62	15.75
N	23	#2	12	11.18	466.85	639.83	447.675	DELCO 19.50	8	16.76	393.675	352.55	18.29	37.08
E	31	#1	12	12.70	530.35	639.83	511.175	#11 1/2	8	10.41	352.400	333.25	39.62	15.75
F	32	#1	12	12.70	530.35	639.83	511.175	#14	8	13.46	466.700	438.15	25.40	29.97
H	35	#1	12	12.70	530.35	639.83	511.175	DELCO 17.75	8	16.76	450.952	393.70	18.29	37.08
J	42	#1/2	12	14.22	619.25	711.20	584.200	#14	8	13.46	466.700	438.15	25.40	29.97
L	45	#1/2	12	14.22	619.25	711.20	584.200	DELCO 17.75	8	16.76	450.952	393.70	18.29	37.08
M	52	#0	16	14.22	679.45	711.20	647.700	#14	8	13.46	466.700	438.15	25.40	29.97
P	54	#0	16	14.22	679.45	711.20	647.700	#18	6	16.76	571.475	543.05	15.75	39.62
S	55	#0	16	14.22	679.45	711.20	647.700	DELCO 17.75	8	16.76	450.952	393.70	18.29	37.08

B-SS525684

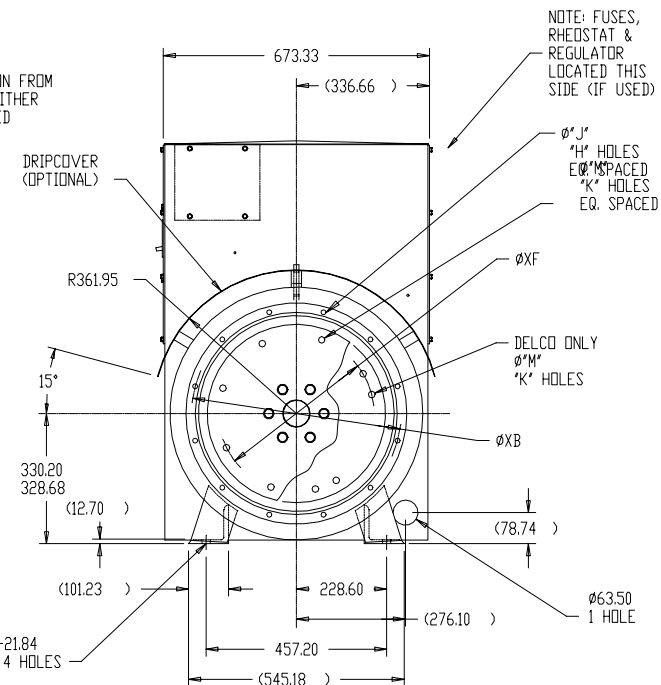
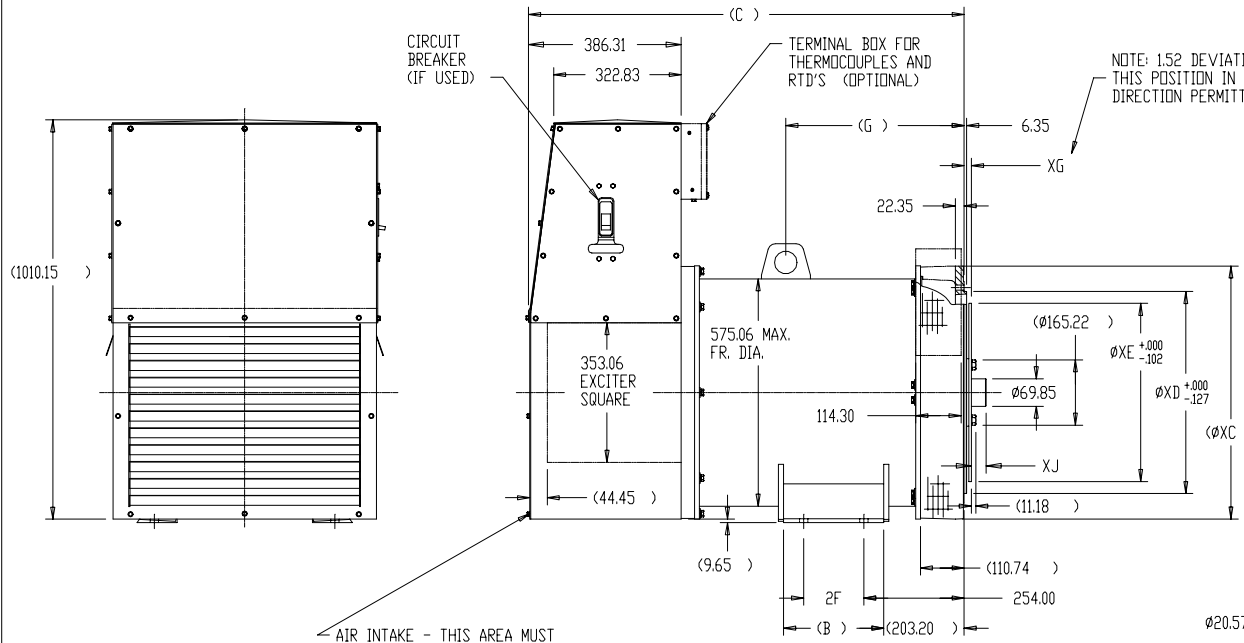
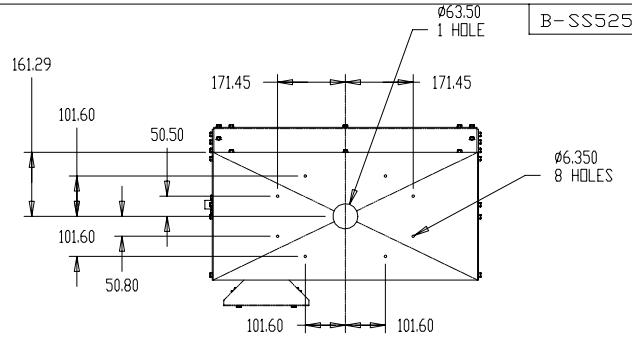

AIR INTAKE - THIS AREA MUST BE FREE OF ANY OBSTRUCTIONS THAT COULD RESTRICT AIR FLOW INTO GENERATOR

DASH	FRAME	C	G	B	2F
175	431	975.36	412.75	254.00	152.40
225	432	1102.36	450.85	254.00	152.40
285	433	1254.76	501.65	381.00	279.40

15	2-12-97	FEET UPDATED TO ANGLE IRON CN 23607	TM	✓ SURFACE ROUGHNESS UNLESS NOTED OTHERWISE	UNLESS OTHERWISE SPECIFIED DIMENSIONS ARE IN MILLIMETERS TOL. ON XX± .76 XXX±.127 XXXX±.0127 ANGLES± 7°30'
14	11-21-95	UPDATE FOOT DETAILS CN 21321	TM	CADD LEVELS 200-449 U.S. CUSTOMARY DIM'S	DRAWN BY TM 6-22-88
13	2-10-93	REV. METER PANEL MTG HOLES CN 15272	TM	CADD LEVELS 450-599 METRIC DIMENSIONS (mm)	CHKD BY FG 6-22-88
REV		CHANGE	NAME	430 FR. MAGNAMAX GEN.	APPD BY LC 6-22-88
			DRWG NO B-SS525684		
SHOPBOOK WA PURCHASED			DISTRIBUTION - WA - LX - WX - X		CADD FILE NO. SS525684

